

THE IM-1BARCODE / B MECHANISM

SET UP AND OPERATION MANUAL

TABLE OF CONTENTS

| | |
|--------------------------------------|----------|
| SAFETY CONSIDERATIONS | 2 |
| UNPACKING | 2 |
| MECHANISM MOUNTING | 3 |
| LOADING / UNLOADING CARDS | 3 |
| CARD THICKNESS ADJUSTMENT | 4 |
| MECHANISM COMMUNICATION SPECS | 5 |
| REGULAR MAINTENANCE | 5 |
| IM-1BARCODE / B CONTROL BOARD | 6 |
| SERVICE LOG SHEET | 7 |
| MACHINE LOG SHEET | 8 |

SAFETY CONSIDERATIONS

Unplug the mechanism when servicing – failure to do this could cause serious injury.

UNPACKING

When the mechanism is received, it should be carefully unpacked and checked closely for any possible damage. If a freight company is involved and there is damage, please notify them immediately. They will need to thoroughly inspect the damage and fill out a report. Please **do not** touch the mechanism until this has been done.

Please remove and save packing materials for later use.

STANDARD MACHINE PACKING LIST

| <u>QUANTITY</u> | <u>DESCRIPTION</u> |
|------------------------|---------------------------|
| 1 | IM-1BARCODE/B mechanism |
| 1 | Hex driver (care package) |
| 1 | Card Weight |
| 1 | Card hook |
| 1 | Warranty certificate |
| 1 | Operation Manual |

MECHANISM MOUNTING

The recommend method of mounting the IM-1BARCODE/B mechanism is to use one rail on each side of the mechanism. The mechanism will easily slide into the rail slot and be mounted by four 8-32 screws on the front face of the mechanism. This system makes for easy installation and servicing if necessary. Other mounting options are available upon request.

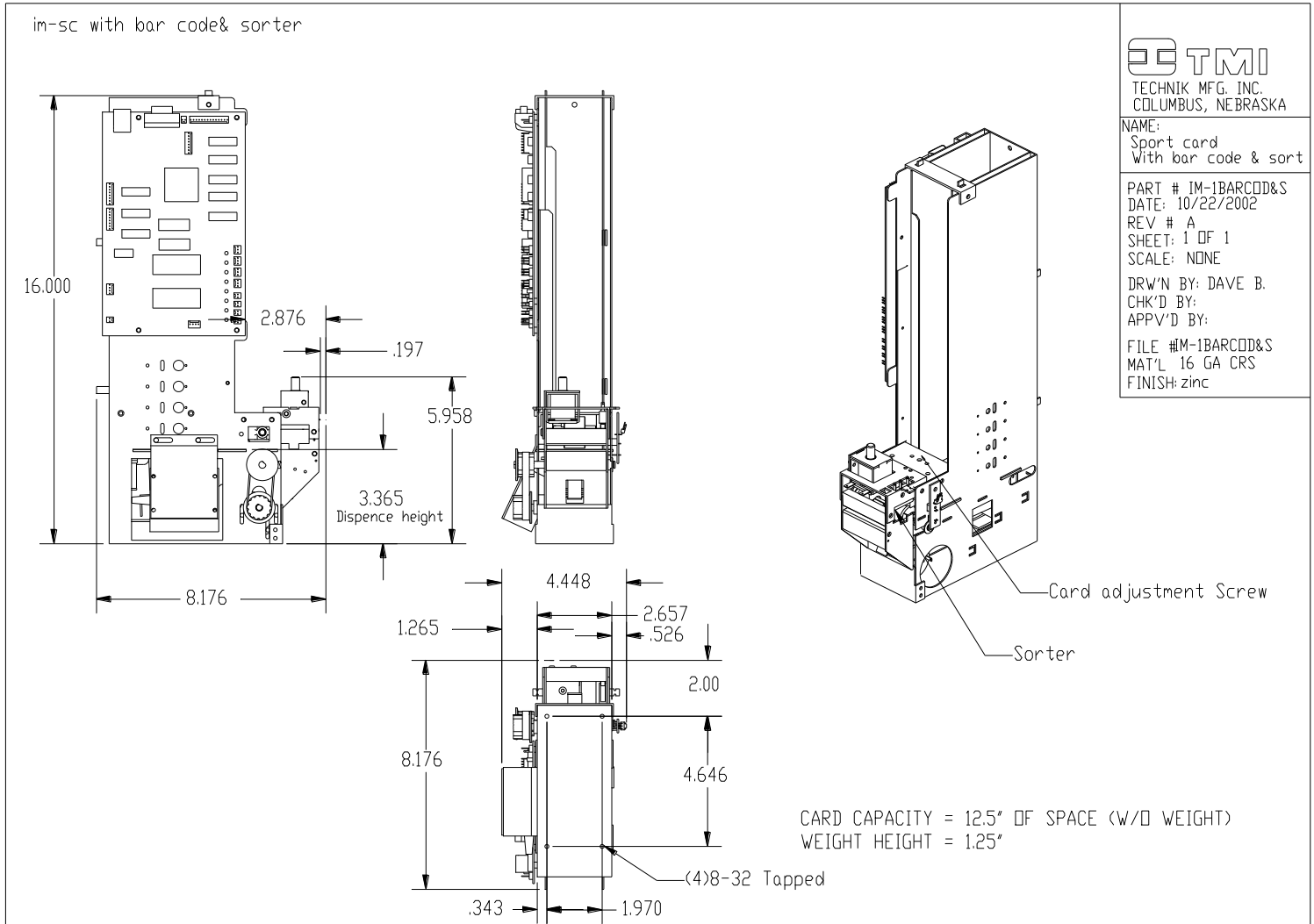

LOADING / UNLOADING CARDS

You are now ready to start loading your cards. The cards must be loaded such that the barcode is facing down and positioned to the left (when facing the mechanism). The card orientation is critical for operation of this mechanism. Once the cards are in place, place a weight on top of the stack. The weight should be in so that the word "FRONT" is facing you, right side up.

For unloading cards, a card hook is provided that allows for easy removal of the bottom-most cards.

CARD THICKNESS ADJUSTMENT PROCEDURE

20 TO 30 MIL CARD ADJUSTMENT

1. Using the hex driver (supplied in the care package), turn the adjustment screw on the dispensing mechanism counter-clockwise until a card will not pass the adjustment mechanism.
2. Place a "test card", tape first, in the bottom of the column you wish to adjust. To make a "test card" place (2) pieces of clear tape or (1) piece of electrical tape as shown below.

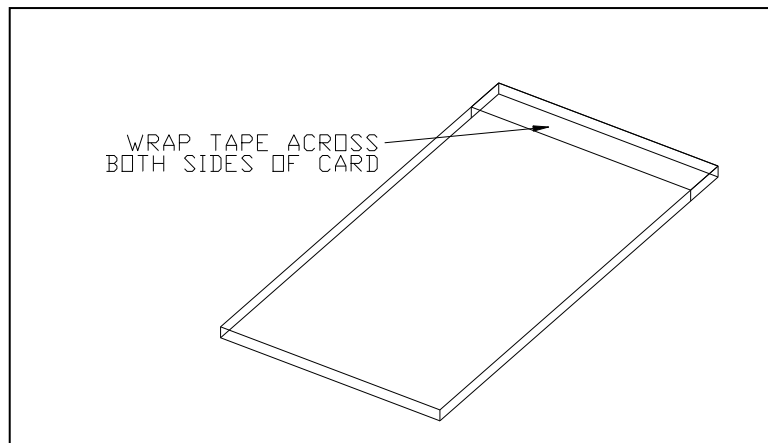

TEST CARD

3. Place the card weight on top of the card.

BEFORE GOING ANY FURTHER, READ THE INSTRUCTIONS BELOW!!!

4. Place the hex head wrench into the adjustment screw.
5. Try to dispense a card and turn the adjustment screw clockwise until a card is dispensed. It may take a few tries before a card is dispensed.
6. Once a card is dispensed, the column is properly adjusted.

10 MIL CARD ADJUSTMENT

1. Follow the procedure described above (20 to 30 MIL CARD ADJUSTMENT) except use a standard 10 mil card (without the tape) for testing.

MECHANISM COMMUNICATION SPECIFICATIONS

The IM-1BARCODE/B mechanism includes the following features as standard:

1. fully functional control board
2. barcode reader
3. card dispenser
4. necessary harnesses

The controller contains firmware to allow a host computer to control the card dispenser by issuing commands through a standard RS-232C serial interface. The communications format for the serial interface is 9600 Baud, 8 bits, no parity, one stop bit. Each message is terminated with a CRC of the message followed by the new-line character. Communication from the controller to the host will be in the form of a fixed format status message. The status message will be sent immediately upon receipt of a command from the host, or whenever a state change occurs on the controller (command completion, reset, and unexpected condition). Call the service number on the front of this manual for any questions.

REGULAR MAINTENANCE

Mechanism Lubrication should not be necessary. Improper lubrication can result in machine malfunction.

IM-1BARCODE/B CONTROL BOARD



NAME:
IM-1XXXB CONTROL BOARD WIRING DIA.

PART # 110-022
DATE: 10/22/2002
REV # A
SHEET: 1 OF
SCALE: NONE
DRW'N BY: KEC
CHK'D BY:
APP'V'D BY:
FILE #
MAT'L
FINISH:

IM-1BARCODE/B CONTROL WIRING DIAGRAM

REVISION HISTORY:

(B) CHANGED CONNECTOR STYLE AT POWER CONNECTION (KEC 9-10-05)

HARD RESET SWITCH
HARD RESET BUTTON

Bill Acceptor
J12
BA PULSE
GROUND
COIN PULSE
GROUND
BA ENABLE
+5 VDC
BA ERROR
+12 VDC

Front Panel
J10
GROUND
SWITCH 0
SWITCH 1
LAMP 0
LAMP 1
OPEN
OPEN
+12 VDC

Bill Acceptor
Front Panel
BA PULSE
GROUND
COIN PULSE
GROUND
BA ENABLE
+5 VDC
BA ERROR
+12 VDC
GROUND
SWITCH 0
SWITCH 1
LAMP 0
LAMP 1
OPEN
OPEN
+12 VDC

TO CARD READ DEVICE
COMMUNICATION CONNECTION
9-PIN (DB9)
BOARD HAS MALE CONNECT

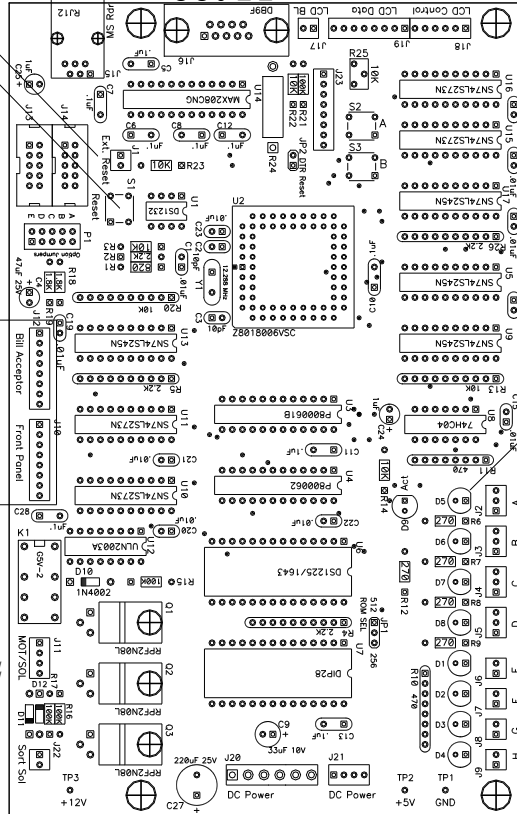

LED DESCRIPTION:
D1 - CARDS SOLD OUT SWITCH
D2 - CARD GATE SWITCH
D3 - OPEN
D4 - OPEN
D5 - CARD DISPENSE SENSOR
D6 - CARD READ SENSOR
D7 - CARD STAGED SENSOR
D8 - CARD LEVEL SENSOR (IF USED)
D9 - ERROR CODE LED

BROWN
BLUE
CARD DISPENSE SENSOR (FS1)

ORANGE
GREEN
CARDS SOLD OUT SWITCH (SOS)

GREEN
CARD GATE SWITCH (VGS)

STANDARD CONNECTOR DESCRIPTION

| ID # | MFG | PN | DESCRIPTION |
|------|-------|--------------|----------------|
| 1 | MOLEX | 22-01-3027 | 2-CIR .100" |
| 2 | MOLEX | 22-01-3037 | 3-CIR .100" |
| 3 | MOLEX | 22-01-3047 | 4-CIR .100" |
| 4 | MOLEX | 22-01-3067 | 6-CIR .100" |
| 5 | MOLEX | 09-50-3061 | 6-CIR .156" |
| 6 | MOLEX | 08-50-0113 | .100" TERMINAL |
| 7 | MOLEX | 08-52-0072-C | .156" TERMINAL |

TYPE #5
TO POWER SUPPLY

TO MOTOR
TO CARD VEND SOLENOID

BLACK
RED
YELLOW

TO SORT SOLENOID

BLUE

